

TETRAPODS

- + Concrete elements for the installation of protection for the maritime works such as breakwaters, diked areas, littoral protection, etc...
- + Other models available upon request (5000 @ 12000kg)

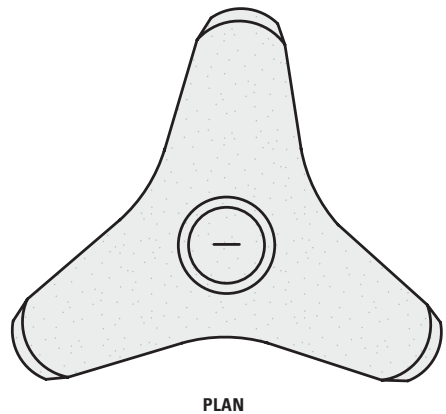
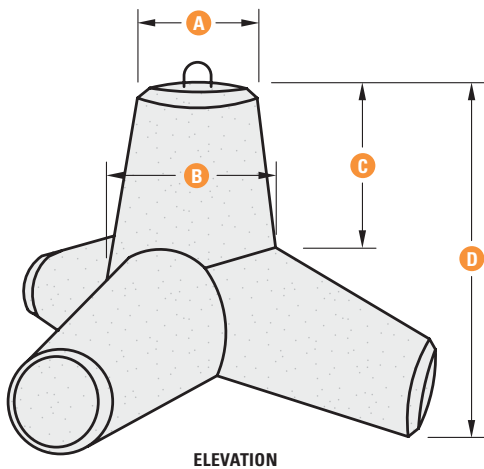
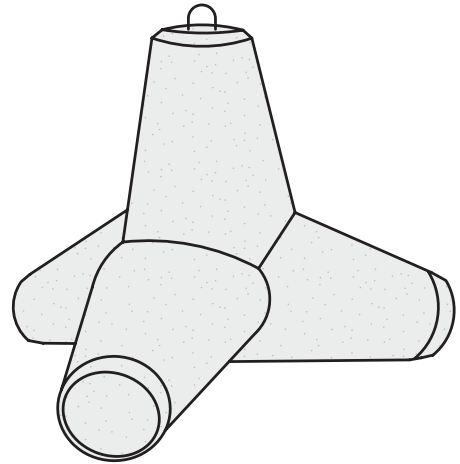

CHARACTERISTICS

	A	B	C	D	
CODE	LENGTH (mm)	LENGTH (mm)	LENGTH (mm)	LENGTH (mm)	WEIGHT (kg)
TETR94	724	1150	1180	2427	9400

* All dimensions are in millimeters.

DOLOSSES

- + Concrete elements for the installation of protection for the maritime works such as breakwaters, diked areas, littoral protection, etc...
- + Other models available upon request (3000 @ 12000 kg)

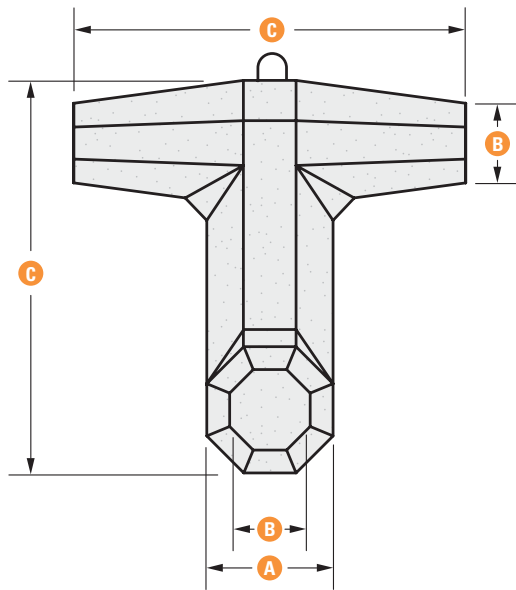

ELEVATION

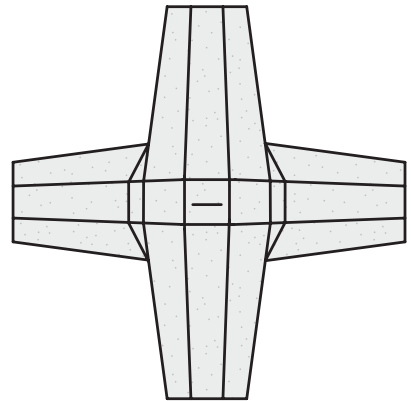
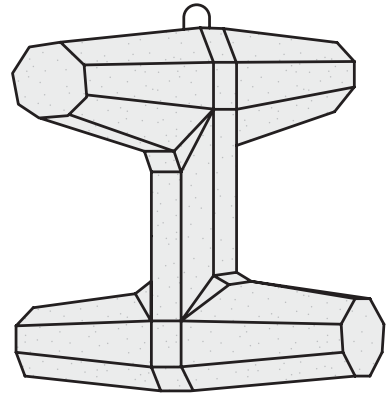

PLAN

CHARACTERISTICS

	A	B	C	
CODE	LENGTH (mm)	LENGTH (mm)	LENGTH (mm)	WEIGHT (kg)
DOL036	685	435	2145	3600
DOL054	940	590	2935	5400

* All dimensions are in millimeters.

BERLIN WALLS

- + Hardware supplied by the customer
- + Structural calculations to be realized by the customer

